

# CARTON & CART STAND: CTPT-1844

APPROXIMATE WEIGHT IS: 92.45 lbs.

\*\*\* ANY ADDITIONS, DELETIONS, OR OMISSIONS MUST BE CORRECTED ON THIS DRAWING AS THIS DRAWING WILL BE CONSIDERED ALL INCLUSIVE \*\*\*

ALL GRAPHICS PROVIDED ARE FOR REFERENCE ONLY. IF CERTAIN DIMENSIONS ARE CRITICAL PLEASE VERIFY THOSE DIMENSIONS WITH YOUR SALESPERSON

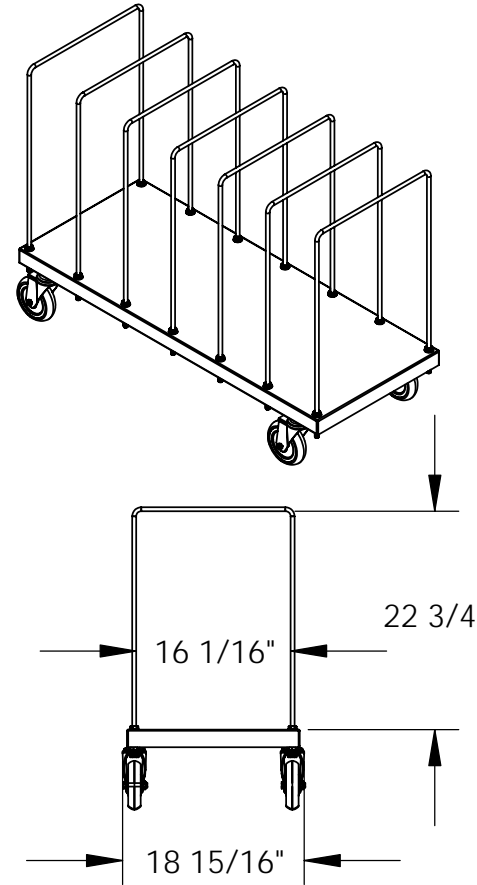
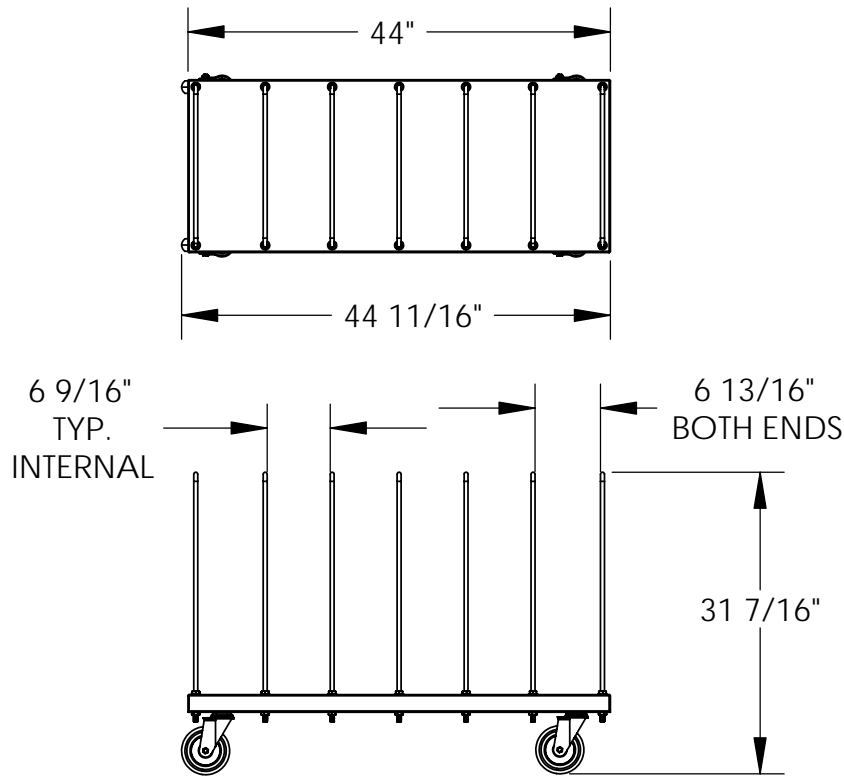

**ALL SPECIAL UNITS ARE NON-RETURNABLE**

<b>A P P R O V A L</b>	I, the undersigned, hereby approve this print. This includes my approval of design & dimensions	
	<input type="checkbox"/> As drawn	<input type="checkbox"/> As marked
	Signed: _____ Date: _____	
<b>LEAD TIME WILL START UPON RECEIPT OF SIGNED APPROVAL DRAWING</b>		

## STANDARD FEATURES

- MODEL NUMBER IS: CPTP-1844
- OVERALL WIDTH IS: 18 15/16"
- USABLE (DECK) WIDTH IS: 16 1/16"
- OVERALL LENGTH IS: 44 11/16"
- USABLE (DECK) LENGTH IS: 44"
- OVERALL HEIGHT IS: 31 7/16"
- 5" DIAMETER SWIVEL CASTERS (x4)

## SPECIAL FEATURES

NONE

DISTRIBUTOR'S NAME: <b>VESTIL MANUFACTURING</b>		P.O.# X
DRAWN BY: T. Moore	DATE: 08/28/08	W.O.# X
REFERENCE: X	QUOTE # X	SALES: X
		FILE NAME: 16-007-160
		SCALE: 1:20